

WE ARE CREATING NEW STANDARDS IN LSR DOSING!



- **High efficiency**
- **Industry 4.0 ready**
- **Compact design**
- **Single and tandem version**

# LSR eTwin Connect

The LSR eTwin Connect represents the new generation of dosing & mixing systems for liquid silicone rubber. It meets the requirements for consistently high productivity and quality at both low and high shot weights. Thanks to the close cooperation with our partners, e. g. injection moulding machine manufacturers, LSR processors and material producers, we can convince with the following features:

## Advantages

- Modern and compact machine design
- Exact mixing ratio
- Up to 99.75% material utilisation
- Process safe and energy efficient pump technology
- Pulsation free volumetric flow
- Industry 4.0 ready
- Updateable software
- 15.6" multi-touch display
- Prozess optimisation
- Intuitive control
- Easy maintenance
- Including automatic drum lock and user-friendly drum unlock device



## Control

- Intuitive HMI
- Clearly arranged multi-touch display
- Process data management
  - User management
  - Recipe management
- OPC-UA
- Machine status display
- Every language possible
- Remote maintenance
- Backup and restore function via USB
- FTP-server for process data retrieval

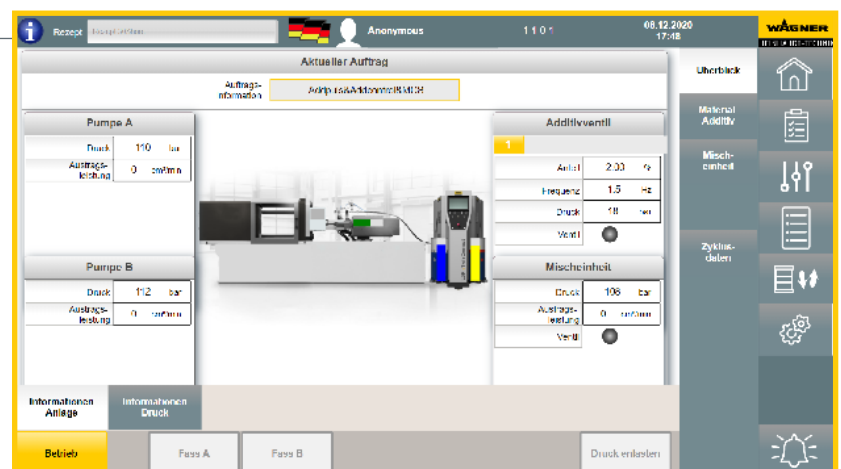

# LSR eTwin Connect

## Pump technology

- Servo driven scoop piston pump
- Up to 80% energy saving compared to air driven pumps
- Process safe technology
- Process optimised (not perceptible changeover point)

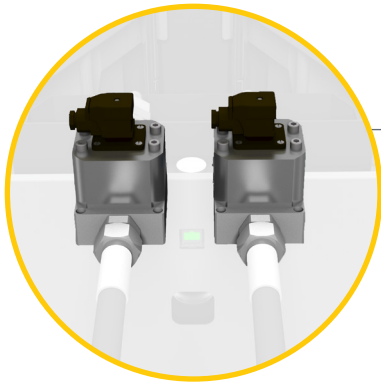
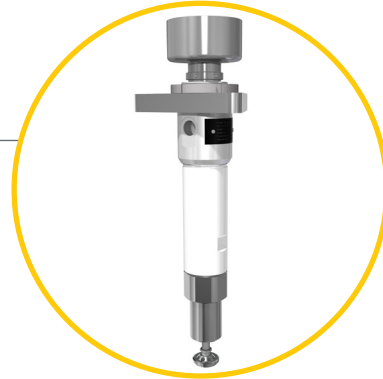

## ABControl

- Additional process monitoring
- Direct volume measurement of the individual components
- Automatic readjustment increases the accuracy compared to the unregulated version.

## Barrel change

### FPAuto

- Automatic follower plate deaeration
- Automatic aeration & deaeration system
- Fast, save and clean barrel change
- Alternative to manual follower plate deaeration (FPManual)



### airAuto

- Volumetric pump deaeration
- Predefinable deaeration volume
- Semi-automation of deaeration process
- Alternative to manual pump deaeration (airManual) and to airTract

# Barrel change

airTract

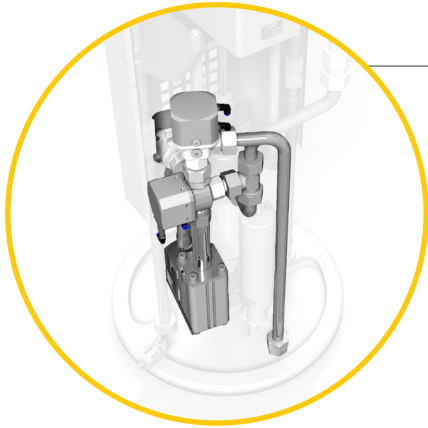

- Patented pump deaeration
- Up to 95% material savings during deaeration process
- Cost saving
- Air free material flow
- Applicable for LSR materials up to 60 Shore A

## Drum insertion device

In many production facilities, there is only little space. Therefore it is necessary to make optimum use of the available space. We invented a flexible system for barrel change for our LSR eTwin Connect.

With the drum insertion device the machine can be placed against the wall with a minimum distance of only 40 cm. The barrel is then changed by crane loading.

- Automatic drum lock
- Drum unlock by foot handling
- Ergonomic and user-friendly
- Via crane or drum lifter

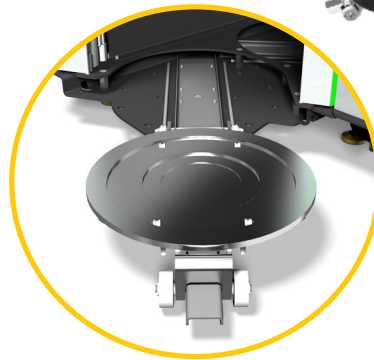

## Drum lifter



- Ergonomic and safe handling of 200 litre drums
- Flexible use for several machines
- Recommended solution for every drum change

# Processing unit

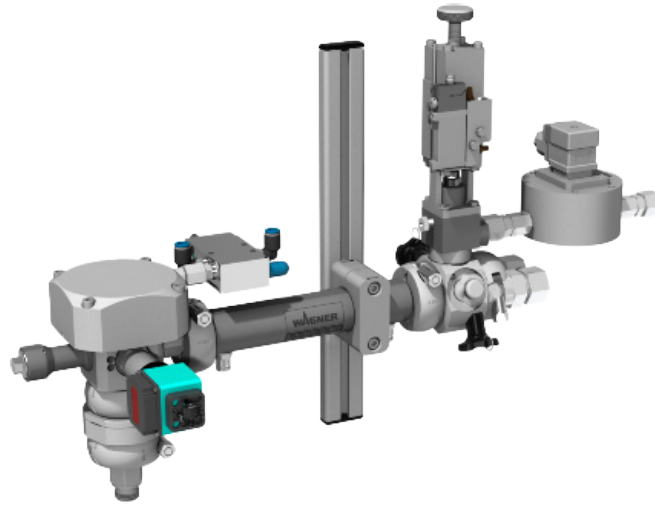

## Advantages

- Easy maintenance
- Modular configuration
- Demountable with only one tool
- Integrated cooling system
- Snuffback valve
- High dosing accuracy with small shot sizes
- Up to 4 additives possible
- Tool free additive change
- Integratable material filter

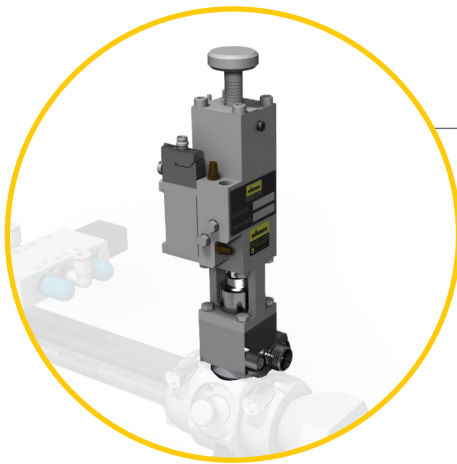

## Additive dosing valve

- Optional up to 4 additives possible
- Long-lasting
- Compact design

## addPulse

- Dosing volume control
- Optimum valve setting
- Automatic additive setting
- Up to 20% higher accuracy compared to standard version
- Combinable with addControl and addPressure



# Additive processing

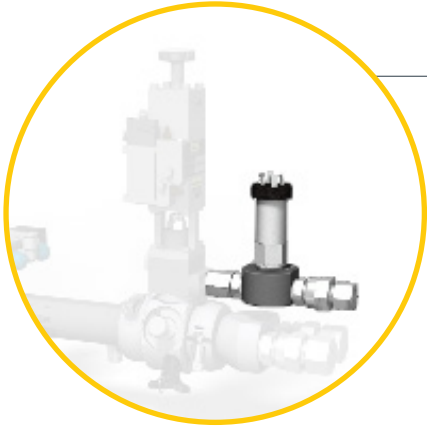

## addPressure

- Pressure monitoring
- One addPressure per additive metering valve provided
- Monitoring of additive supply pressure
- Increase of process reliability
- Combinable with addPulse
- Recommended for additives with high concentration of fillers
- Alternative to addControl

## addControl

- Dosing volume control
- Direct volume measurement
- Continuous additive regulation
- Highest dosing accuracy and reproducibility
- Additive savings possible
- One addControl per additive dosing valve provided
- Combinable with addPulse

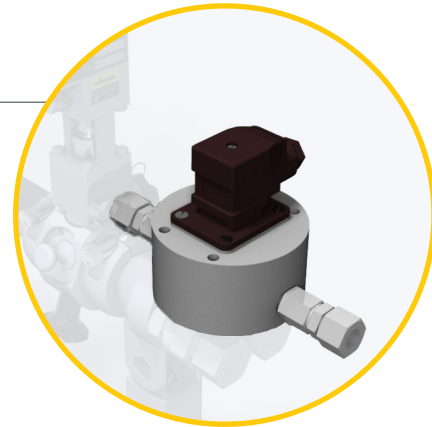

## Additive feeding - mini

- Mobile additive feeding
- Easy handling of material pressure vessels for additives
- 1 litre container
- Charging pressure up to 6 bar

## Additive feeding - midi

- Mobile additive feeding
- 10 litre container
- Charging pressure up to 24 bar



# Additive processing



## Additive feeding - maxi

- Mobile additive feeding from 20 litre hobcock with drum cover
- Flexible use
- High charging pressure for long distances

## Further LSR variants

### Tandem version

- Every machine can also be used individually
- No production stop due to barrel change
- Gain of production time (min. 10 minutes per barrel change compared to single version)



### 20 litre follower plate

- For the processing of 20 litre hobcocks
- For configuration as a pure 20 litre dosing system or as a conversation kit to 200 litre variant

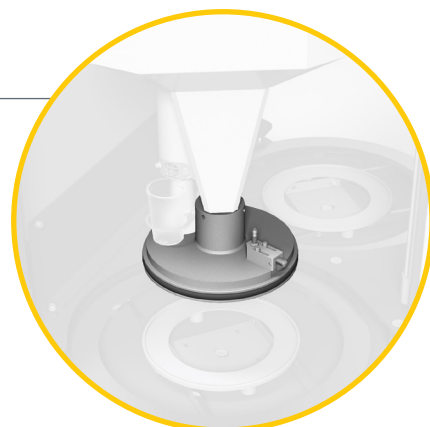

<sup>1</sup> depending on various factors e. g. material properties and other parameters

<sup>2</sup> compared to manual aeration



# YOUR GLOBAL PARTNER IN LIQUID SILICONE INDUSTRY

Processing single or multi-component liquid plastics for LSR injection moulding, bonding, sealing, casting and encapsulation as well as surface treatment applications are our well recognized core competences - combined with system integration and process control.

What started in 1962 with a team of ambitious engineers has grown over half a century to a leading global supplier of metering and mixing equipment with a proven record of innovative solutions in the market.

Reinhardt-Technik is a preferred supplier of dosing and mixing systems for various industries for decades. Experience, profound engineering know-how and global service has made us a partner for many injection molders as well as injection molding machinery manufacturers. We understand the requirements and provide the most beneficial solutions.

As technology leader in the field of LSR processing as well as adhesive and sealant processing, we have been part of J. Wagner GmbH since 2012.

Wagner is a leading manufacturer of surface technologies with more than 1,700 employees globally and headquarter in Markdorf on Lake Constance, Germany.